

HOLLOW GRINDER



HOLLOW GRINDER

Models HG4CU and HG6CU

COZZINPRIMEEdge
CUTTING EDGES AND SHARPENING SOLUTIONS



Unique cup wheel sharpening stone design assures consistent grind bevel widths.

- Ideal for high-volume knife users.
- Available with Ø4" (102 mm) or Ø6" (152 mm) cup stones.
- Thins blades for edging up to 16" (406 mm) long.
- Recirculating liquid coolant system provides burn-free and dust-free operation.
- Integrated, pneumatically-controlled, stone dressing system maintains roundness of the cup stones for perfect, consistent, sharp edges.
- Built-in Go/No-Go gauge determines at a glance if the blade is thinned enough for edging and honing.
- CE approved.

Sharpening machines and edge maintenance tools

Plates, knives, inserts and blades

Sharpening service

COZZINPRIMEEdge
CUTTING EDGES AND SHARPENING SOLUTIONS

HOLLOW GRINDER

For efficient, high-volume knife sharpening operations, Cozzini HGCU Grinders are used to thin blades prior to edging and honing. 4" (102 mm) or 6" (152 mm) cup stones provide the unique advantage of maintaining the same stone bevel and diameter as the stones wear, thereby assuring a consistent grind bevel width. When combined with our Honer/Edger (HE7) as part of a centralized knife sharpening system, productivity increases and ergonomic problems decrease.

The ergonomic design of the Hollow Grinder provides operator comfort and safety. An adjustable, pivoting lamp can be oriented in different positions for excellent visibility while grinding blades. The sturdy stainless steel body with fiberglass cover provides long life and easy maintenance access.

For a consistent and precise blade thinning operation, trust the proven HGCU series of Grinders from Cozzini.

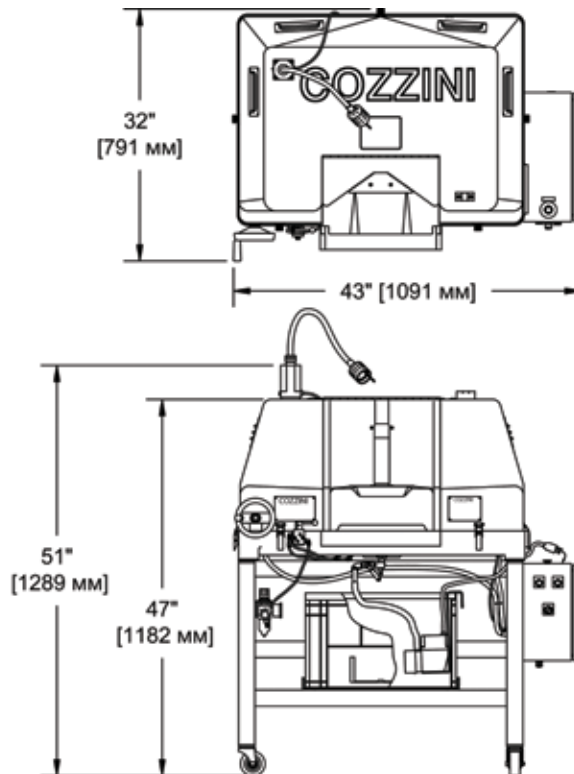

HOLLOW GRINDERS				
<i>Model</i>	<i>Voltage</i>	<i>Phase</i>	<i>HP</i>	<i>kW</i>
HG4CU	220 V	1	.50 (x2)	.4 (x2)
	230/460 or 380 V	3	.50 (x2)	.4 (x2)
HG6CU	220 V	1	.75 (x2)	.6 (x2)
	230/460 or 380 V	3	.75 (x2)	.6 (x2)

4300 West Bryn Mawr Avenue Chicago, IL 60646-5943 U.S.A.

COZZINIPRIMEEdge
CUTTING EDGES AND SHARPENING SOLUTIONS

877-322-EDGE (3343) | primedge.com | sales@primedge.com