

HG4S-B POLISHER/BUFFER



HG4S-B POLISHER/BUFFER

COZZINIPRIME**Edge**
CUTTING EDGES AND SHARPENING SOLUTIONS



Buffing wheels

- Polishes and removes grinding marks from both sides of a blade simultaneously in a matter of seconds.
- Polishes blades up to 10" (254 mm) long.
- Smooth blade edges increase productivity by reducing knife drag through product, making cutting easier and increasing production.
- CE approved.

HG4S-B POLISHER/BUFFER

A complementary unit to any Cozzini sharpening system, the HG4S-B Polisher/Buffer delivers a smooth and polished edge on each blade.

The Ø4" (102 mm) buffing wheels eliminate grinding marks and produce a smooth, polished surface. In a meat processing line, polished knife edges boost productivity by reducing blade friction and operator elbow/wrist fatigue.

The Polisher/Buffer consists of a cast aluminum body housed under a durable, easy-to-clean, fiberglass cover. The ergonomic design of the Polisher/Buffer provides operator comfort and safety. An adjustable, pivoting lamp can be oriented in different positions for excellent visibility while polishing blades. Each unit is equipped with a cart for easy portability.

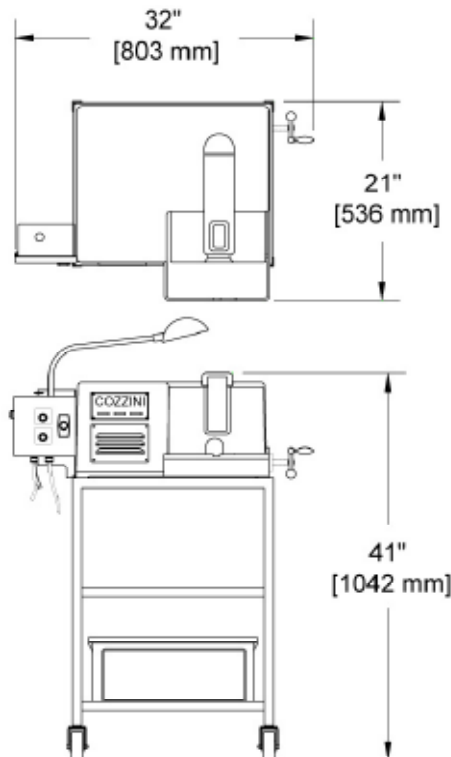

HG4S-B POLISHER/BUFFER

<i>Voltage</i>	<i>Frequency</i>	<i>HP</i>	<i>kW</i>
115 V	50 or 60 Hz	.5	.37
220 V			