

# HES-3 Ergo Steel III

*The Next Generation Of Edge Maintenance Innovation*



**ERGO**<sup>®</sup>  
STEEL III



**COZZINI**PRIME**Edge**  
CUTTING EDGES AND SHARPENING SOLUTIONS

## HES-3 Ergo Steel III

- Perfect edge in seconds.
- Aligns both sides of the blade simultaneously.
- Straightens and prolongs the edge life of all knives.
- Ideal for all types of small and large knives.
- Safety-shield handle provides comfortable and safe, right or left handed use.
- Totally enclosed, sanitary spring mechanisms.
- Easy maintenance and cleaning.
- USDA and CE approved.

# HES-3 Ergo Steel III

**W**hether you process chicken, beef, pork or fish, keeping knife edges sharp is essential on the processing line. With use, sharp knives will dull. The **PRIMEEdge** Ergo Steel III is a fast and easy way to straighten and restore those knife edges for razor-sharp performance. The Ergo Steel III is an edge maintenance tool used on the production floor. Throughout the day, as a knife edge dulls, the operator can slide the blade through the unique spring-tensioned rods of the Ergo Steel III and straighten the edge in a matter of seconds.

The Ergo Steel III consists of a pair of pivoting, hardened stainless steel, tempered rods on a food-grade, molded polypropylene base. Under each pivoting rod, fully enclosed spring mechanisms provide the perfect amount of tension between the knife edge and stainless steel rods. Both sides of the edge are straightened simultaneously, assuring a perfect edge in seconds.

Requires no training to use, the Ergo Steel III can be held comfortably and safely, right- or left-handed. The Ergo Steel III's handle can be effortlessly placed into the optional stainless steel bracket for bench-mount use.



Use hand-held, right or left handed



Bracket installed for use at work table height



Bracket installed for use at elevated height

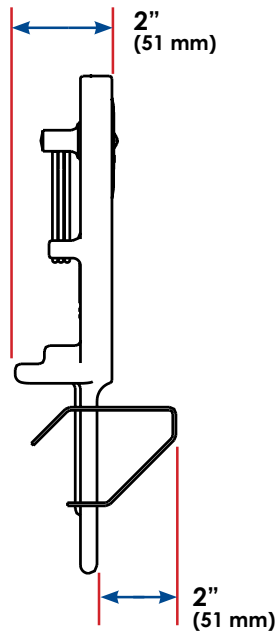
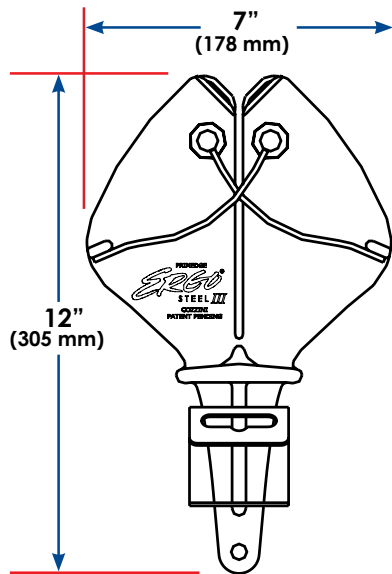

Available in white, yellow or blue

Color	PRIMEEdge Part No.
White	HES-3
Yellow	HES-3AM
Blue	HES-3BL

**COZZINI PRIMEEdge**  
CUTTING EDGES AND SHARPENING SOLUTIONS

877-322-EDGE(3343) • primedge.com • sales@primedge.com • Fax:773-478-6940

PRIMEEdge, Inc. • Cutting Edges • Knife Sharpening Systems • Edge Maintenance Tools • Professional Sharpening Services  
Circular Blade & Grinder Plate Sharpeners • Grinder Plates, Knives & Accessories • Sanitizer/Bacteria Reduction Washing Systems